

RF50-FR

Rear Fixed 50mm Fire Rated Rainscreen System

CWCT Certificate of Testing 20/113

Hamilton

METAL FORMING LTD

SPANWALL 
RAINSCREEN SYSTEMS

www.hamiltonmetalforming.com

Certificate of Testing





Certificate Number: 20/113
Date: 23 March 2021
System: Spanwall RF50 FR Rainscreen
System supplier: Hamilton Metal Forming
47 Shivey Rd, Cookstown

Tests performed:

| | |
|----------------------------------|---|
| Air permeability | ✓ |
| Watertightness - static | ✓ |
| Watertightness - dynamic | ✓ |
| Watertightness - hose | ✓ |
| Wind resistance - serviceability | ✓ |
| Wind resistance - safety | ✓ |
| Soft body impact | ✓ |
| Hard body impact | ✓ |

In accordance with 'Standard for Systemised building envelopes', and 'Standard test methods for building envelopes', CWCT, 2006

Signed:  **Test Engineer**

Signed  **Director**

CWCT Services Ltd, The Studio, Entry Hill, Bath, BA2 5LY
Tel: 01225 330945, email: cwct@cwct.co.uk
www.cwct.co.uk

Description of components tested

Rainscreen system: RF50 FR rainscreen.

Panel material: 3mm 3103 H14 mill finish aluminium.

Panel descriptions: 50mm deep cassettes formed from aluminium flat sheet by folding edges of panel.

Sides of panels double folded with return extending 45mm under cassette. Punched slots in return engage with hooks on vertical rail to support panel. Punched slots 50mm from top and 113mm from bottom of cassette and at maximum 800mm centres.

Top of panel double folded with upstand of 50mm forming labyrinth joint with bottom of panel above. Screw fixings through upstand into support rail to secure cassette against uplift.

Aluminium top hat intermediate vertical stiffeners formed by folding 3mm aluminium sheet. Top hats 45.5mm deep with 100mm wide raised section and 20mm wide flanges. Flanges of top hat are attached to the panel with 3M VHB tape. Pairs of slots in top of section to engage with hooks on support rails at same spacing as panel edges.

| Panel size: | Width (mm) | Height (mm) | Stiffeners |
|-------------|------------|-------------|--------------|
| | 1830 | 3360 | 1No vertical |
| | 2150 | 500 | 1No vertical |
| | 1830 | 3680 | 1No vertical |
| | 320 | 3680 | None |
| | 320 | 2180 | None |
| | 3830 | 1860 | 2No vertical |
| | 3830 | 320 | 2No vertical |
| | 3830 | 500 | 2No vertical |
| | 2946 | 1180 | 2No vertical |

Joints: Labyrinth horizontal joints formed by upstand at back of lower panel.

Closed vertical joints formed by return at edge of panel bearing against bubble gasket on vertical support rail.

Certificate Number 20/113

| | |
|---------------------------|---|
| Support system: | <p>Extruded aluminium vertical rails ref 504FR supported by 300mm Spanwall rainscreen brackets.</p> <p>Rails supplied in lengths of up to 2487mm. Each section of rail fixed with one deep bracket at approximately the mid point to transfer wind and vertical load. Remaining brackets carry wind load only and allow vertical movement. Joints between sections of rail connected with sliding interface to allow vertical movement. Brackets at maximum spacing of 445mm.</p> <p>Rails fixed to brackets by 5.5 x 28 S/S Self Drilling Hex Head screws, 2 fixings per bracket for wind load brackets, 4 No fixings per bracket for dead load brackets.</p> <p>Support rails aligned with panel edges and vertical stiffeners.</p> |
| Panel fixings: | <p>Panels supported by hooks attached to vertical rails. Hooks formed from 3mm aluminium. Hooks attached to rails by a single M8 stainless steel bolt. Bolt head engages in a race on the side of the rail permitting vertical adjustment. Hook fits against outstand on side of rail preventing rotation of hook under load.</p> |
| Drainage and ventilation: | <p>Drained and ventilated cavity behind rainscreen.</p> <p>Horizontal labyrinth joints between panels provide ventilation. Flashings required above windows and at base of wall to drain water from cavity.</p> <p>8.5mm weep holes in return at bottom of panels to provide drainage of cassettes.</p> |
| Backing wall: | <p>Backing wall formed from SFS studs 204MM SFS U TRACK 2.0G (70) 204MM SFS U TRACK 1.2G (40) 200MM SFS C STUD 2.0G 4178 200MM SFS C STUD 2.0G 3542 BS:5950-5</p> <p>Backing wall constructed in two sections separated by horizontal steel support beam. Lower section 4178mm high and upper section 3542mm high. Window located towards the bottom of the upper section.</p> <p>12mm RCM Y-wall sheathing on external face of studs. Joints between boards sealed with sealant</p> <p>Proctor Procheck FR200 membrane on face of sheathing. Membrane fixed at the top bottom and joints with foil tape, and held in place when installing with sealant used for Y-wall joints.</p> |
| Window opening | <p>Aluplast uPVC window included in specimen. Window included to assess sealing of interface between window and backwall/rainscreen.</p> |

Certificate Number 20/113

Seal between window frame and backing wall formed by EPDM flashing. Flashing sealed to outer face of window frame with Soudal Fix ALL sealant and sealed to FR200 membrane with foil tape. Additional Soudal Fix ALL sealant between window frame and steel studs around inside of window frame.

Rainscreen sealed to face of window frame with Spanwall F section profiles and Soudal Fix ALL sealant.

Summary of Results

Air permeability: PASS

Pressure: 600Pa infiltration
100Pa exfiltration

Leakage rate (max): 0.70m³/hr/m² infiltration (at 600Pa)
0.20m³/hr/m² exfiltration (at 100Pa)

Watertightness – static: PASS

Test Pressure: 600Pa

Watertightness - dynamic: PASS

Note: During the test some water was blown across the rainscreen cavity causing wetting of the face of the back wall but no water was present on the internal face of the specimen.

Watertightness – hose test: PASS

Hose test carried out on interface between window and rainscreen. No water was observed on the inside of the sample.

Wind resistance: PASS

Serviceability test pressure: 2400 Pa

Safety test pressure: 3600 Pa

Wind load applied to backing wall and separately to rainscreen.
Details of deflection measurements given in Table below.

Impact:

Soft body impact test to CWCT Technical Note 76

No damage observed.

Each location subject to 3No impacts at 120Nm, followed by one at 500Nm

Tests carried out at the following locations:

Panel H01

- Top corner of panel
- Bottom corner of panel
- Middle of central bay
- Top edge of panel in middle of central bay

Panel D02

- Edge of panel at mid height
- Over central stiffener at mid height
- Over central stiffener near bottom edge of panel.

Note: The most vulnerable location for this type of panel is normally near the bottom edge mid-way between supports.

**Hard body test to CWCT
Technical Note 76**

No damage observed at 6No locations. At the final location a small dent formed which was only visible from within 5m.

Each location subject to one impact at 10Nm.

Tests carried out at the same locations as soft body tests.

Notes:

Serviceability performance is given in 5 classes; Class 1 is the highest class and indicates that no visible damage was caused by the impact. Class 2 indicates that minor damage was caused which was only visible from within 5m and is unlikely to require remedial action.

Safety performance is given in four classes. Negligible risk is the highest performance class and indicates that no debris fell from the specimen during the test and the panel remained secure although some distortion is permitted which could require replacement of the panels.

Wind resistance test results

| Wind load applied to back wall | | | | | |
|---|--|-----------|-------------------------------------|-------------------------------|---------------|
| Location | | Span (mm) | Deflection limit (span/360) or 10mm | Measured deflection at 2400Pa | |
| | | | | Positive (mm) | Negative (mm) |
| Lower section of wall with stud spacing 635mm | | 4178 | 10 | 5.6 | 6.1 |
| Maximum residual deflection after removal of load 0.3mm | | | | | |

| Wind load applied to rainscreen panels | | | | | Measured deflection at 2400Pa (3) | | Residual deflection on unloading (3) | |
|--|------------------------|-------------------------|---------------|-------------------------------------|-----------------------------------|----------|--------------------------------------|----------|
| Panel Ref | Width (panel/bay) (mm) | Height (panel/bay) (mm) | Span (1) (mm) | Deflection limit (span/90) (2) (mm) | Pos (mm) | Neg (mm) | Pos (mm) | Neg (mm) |
| H01 | 3830/1277 | 1680 | 1985 | 22.1 | 14.1 | 13.9 | 0.3 | 0.5 |
| A01 | 320/320 | 3860 | 3630 | 40.3 | 3.6 | 2.8 | 0.2 | 0.2 |
| D02 | 1830/915 | 3860 | 3700 | 41.1 | 27.0 | 27.2 | 0.4 | 0.5 |

Notes:

- (1) Span taken as diagonal dimension of panel or bay of panel for panels with stiffeners.
- (2) Span/90 is the limit given in the CWCT Standard. Failure to recover from deflection on unloading may indicate plastic deformation which could lead to fatigue failure after a number of load cycles. CWCT standard limits residual deflection to 1mm.
- (3) Deflection is the maximum movement at the centre of the bay relative to movement at corners of bay. Positive wind load is for pressure on outside face of sample greater than pressure on internal face of sample. Negative pressure is pressure on outside face of sample less than pressure on inside face of sample.

Due to connection between back wall and support rails and connection of support rails to panels, wind load on panels will be transferred to back wall. Deflection of rainscreen panels will therefore be affected by stiffness of back wall. Panel H01 located in an area of the sample where the deflection of the back wall was measured. Panels A01 and D02 located in areas with closer spacing of studs in back wall.

Drawings

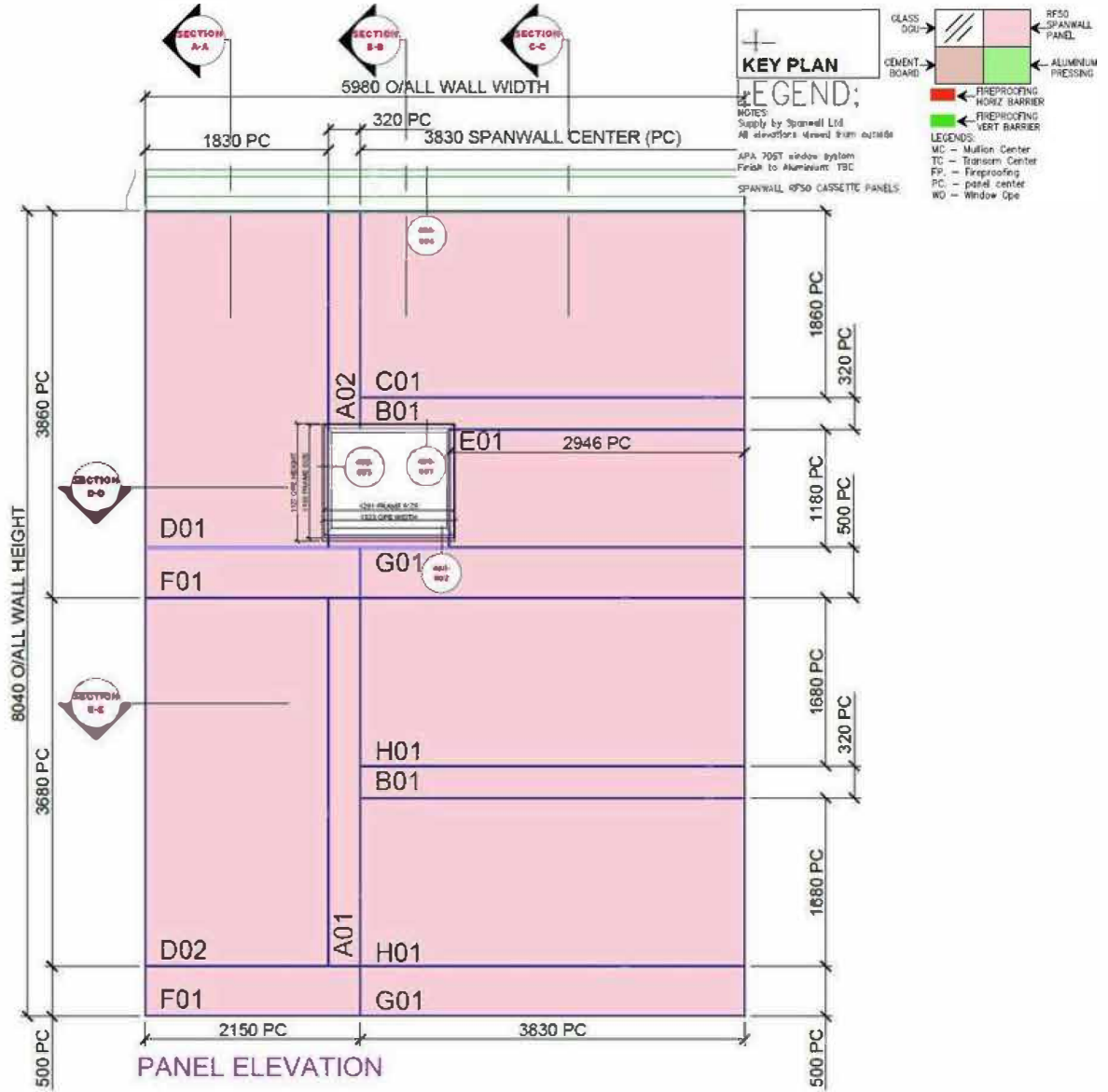

Elevation of test wall showing cassette arrangement

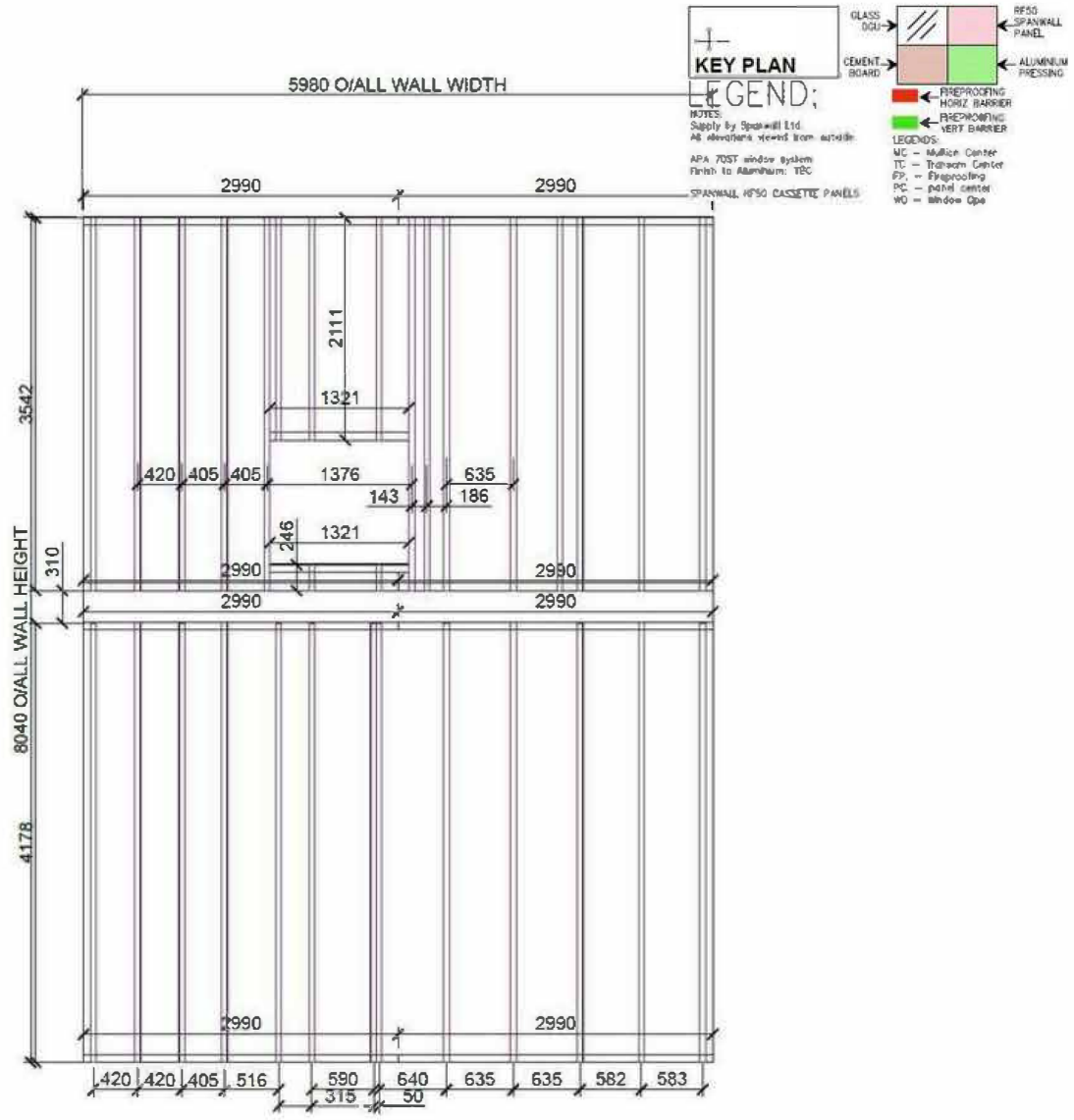

Elevation of sample showing SFS arrangement

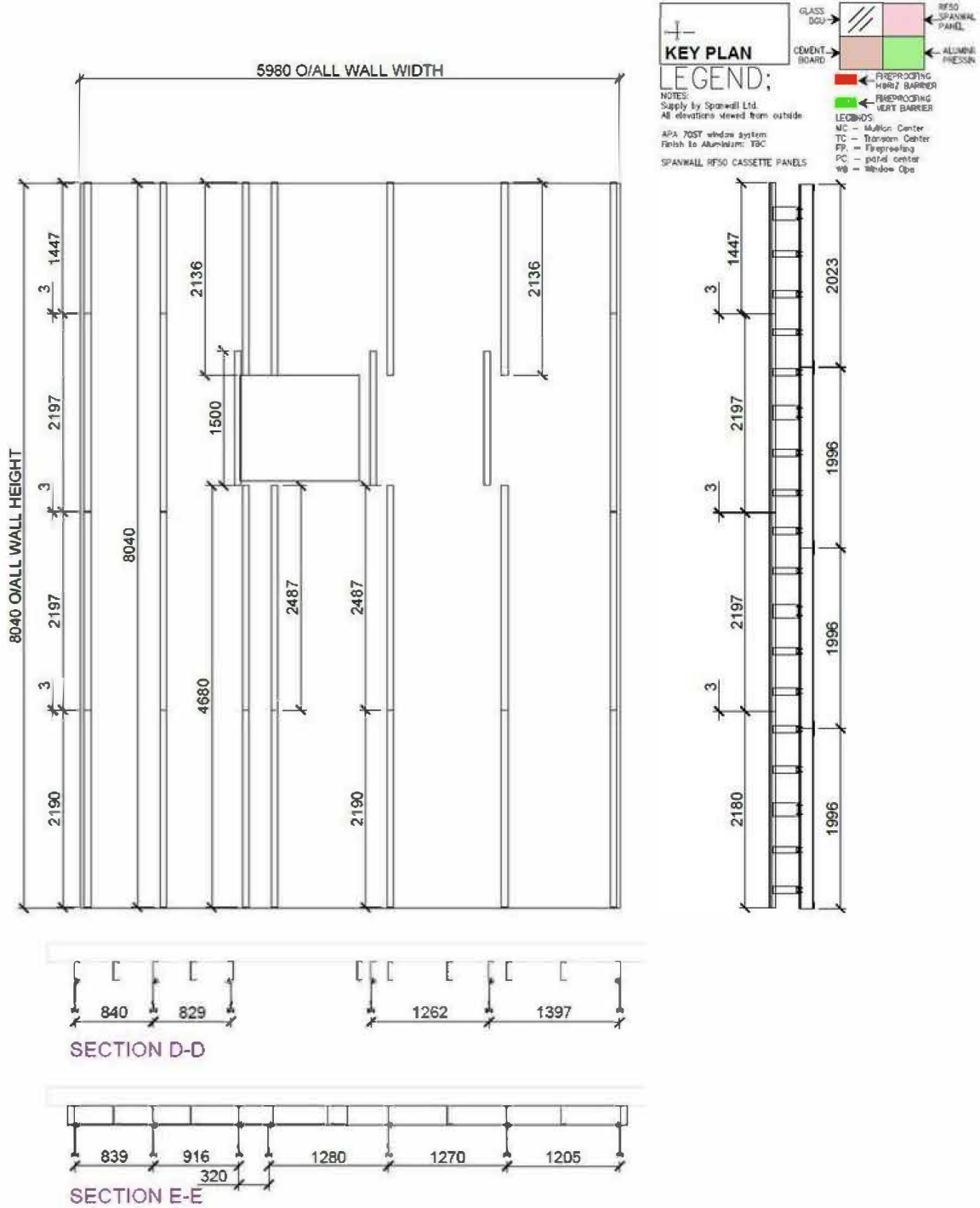

Rainscreen support rail arrangement

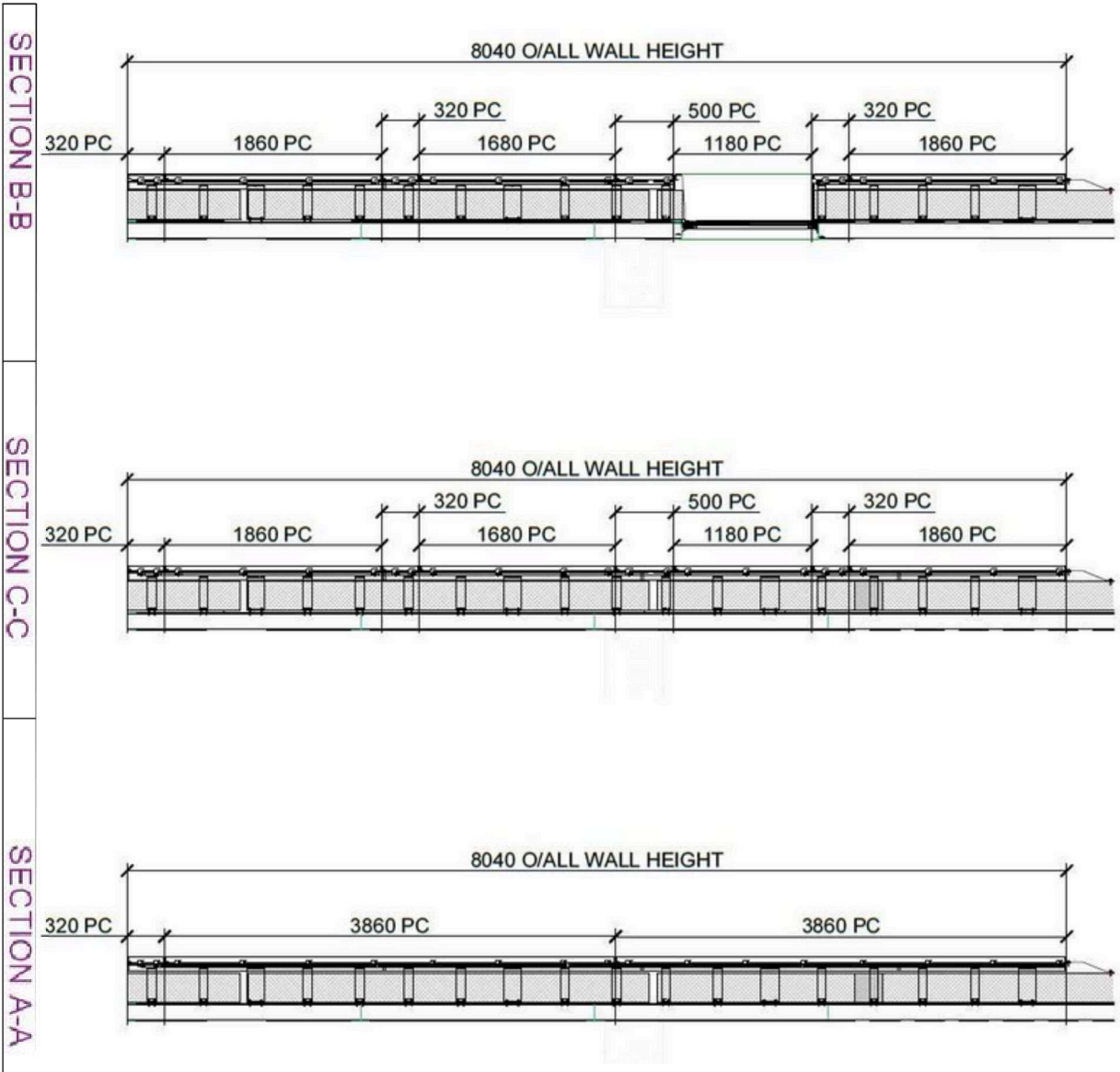

Vertical sections through sample.

Certificate Number 20/113

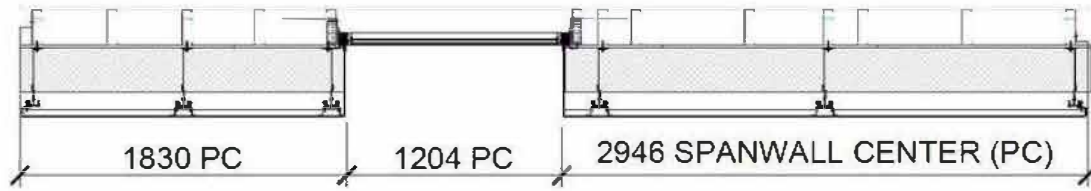

SECTION D-D

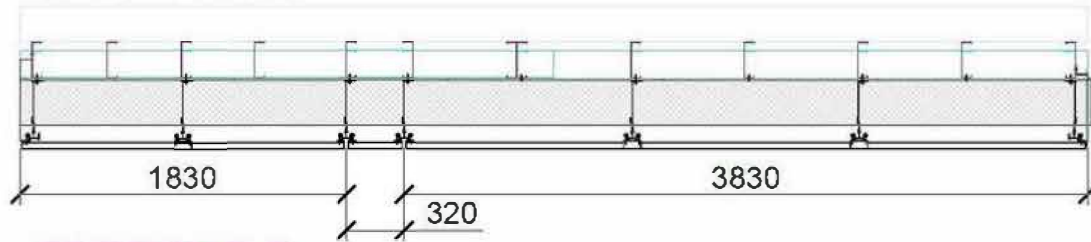

SECTION E-E

Horizontal sections through sample

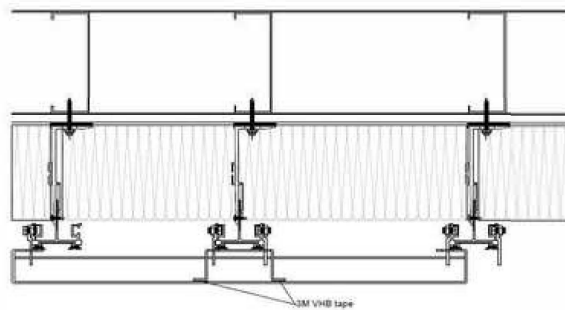
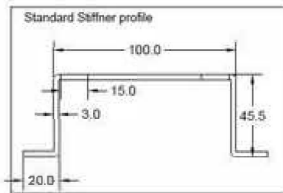
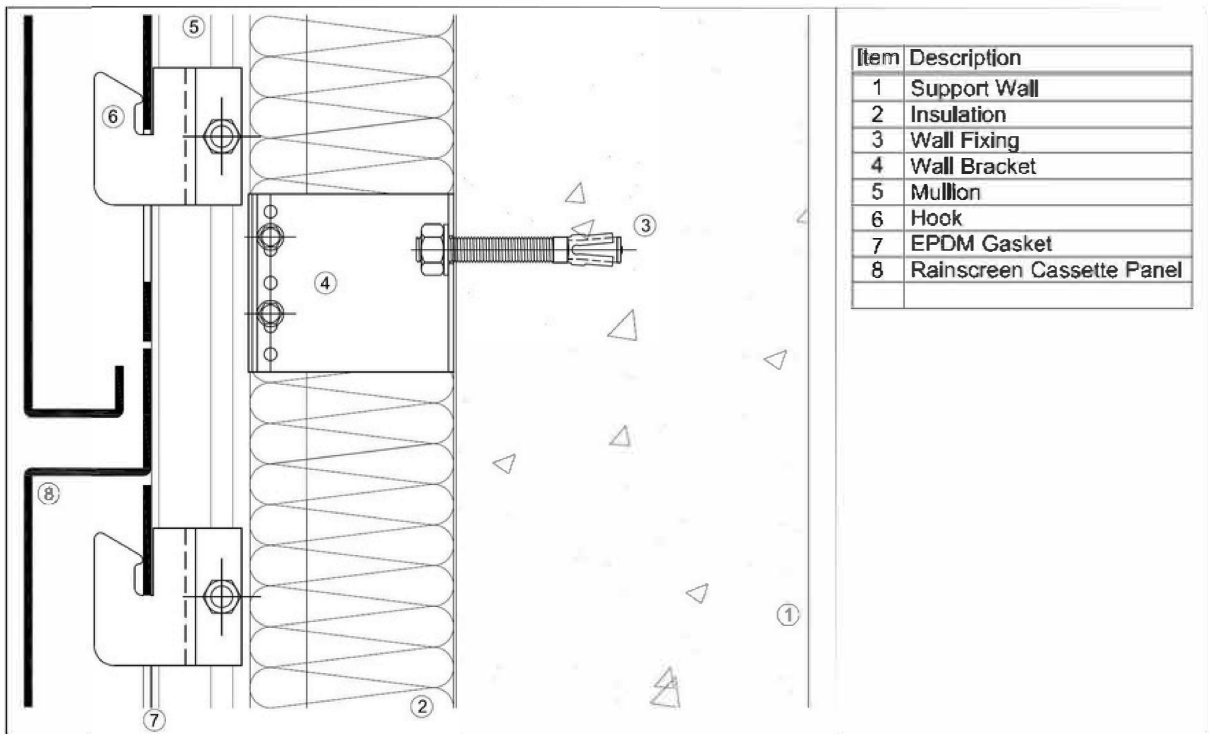

Panel lengths over 1500mm require a stiffener.
 > 1500 ≤ 3000 = 1 central stiffener.
 > 3000 = 2 equally spaced stiffeners.
 For panels over 3m please contact the sales team.

Panel heights over 1000mm require extra hooks

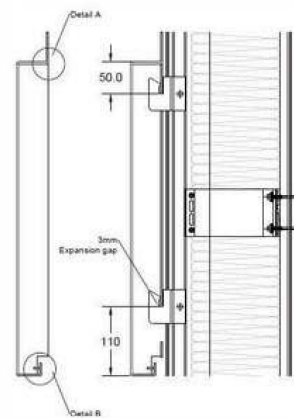
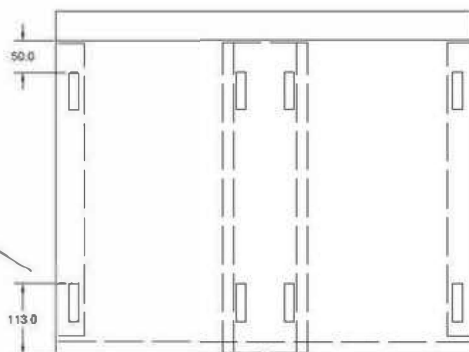
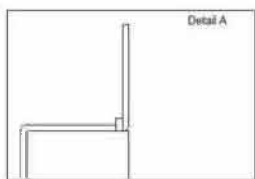

Note - 3mm expansion allowed for dry gasket

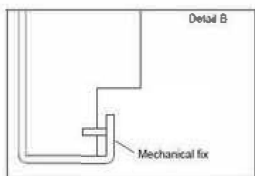

Details of rainscreen system

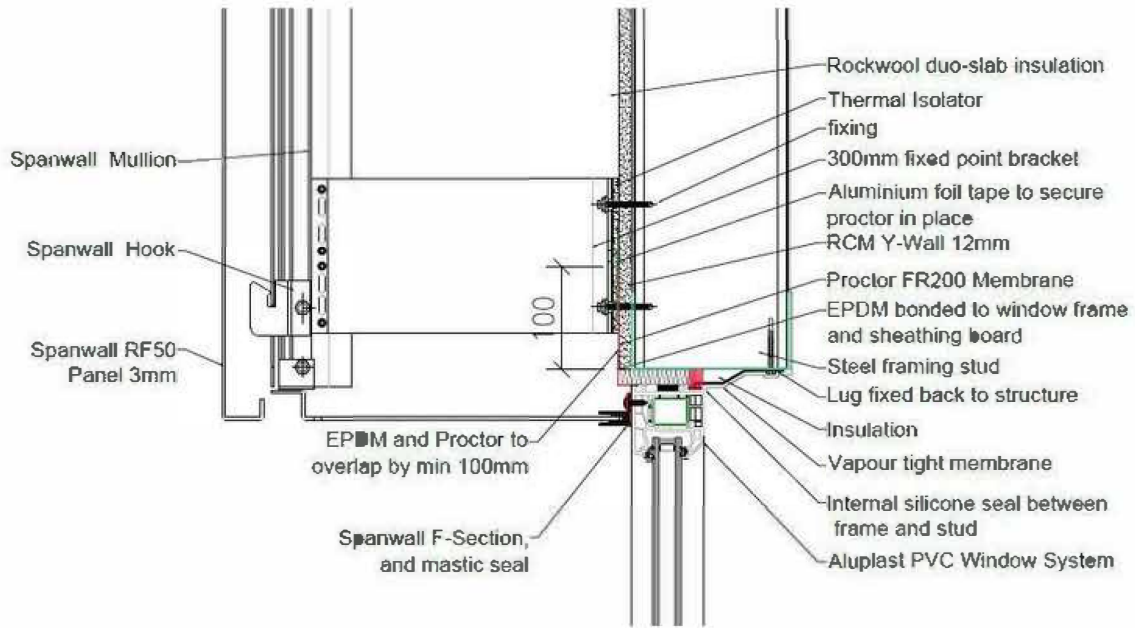

Window head detail

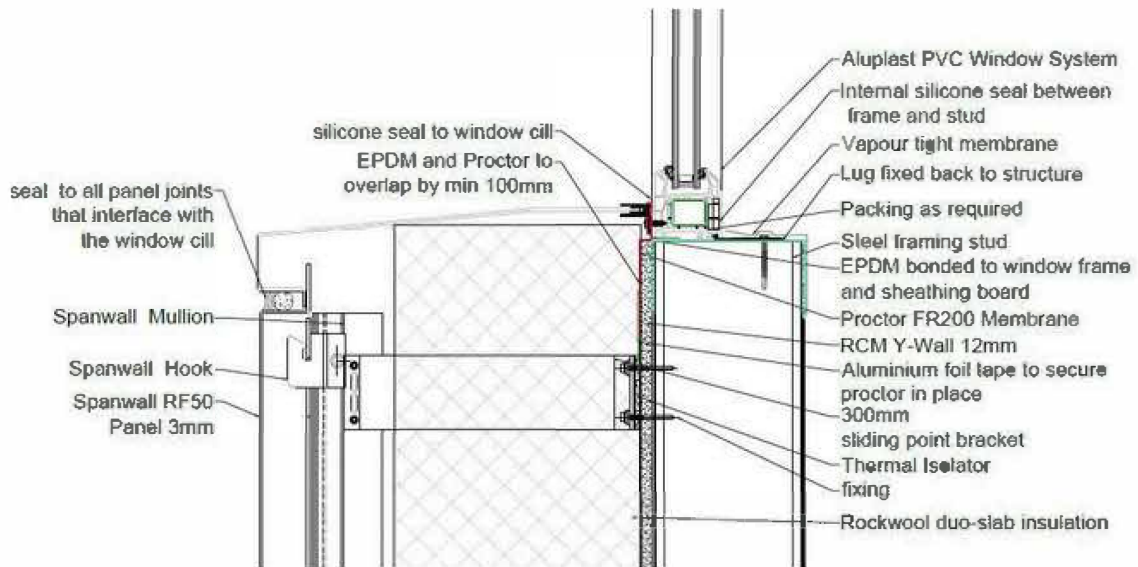

Window cill detail

Note: vapour tight membrane omitted from test sample internal

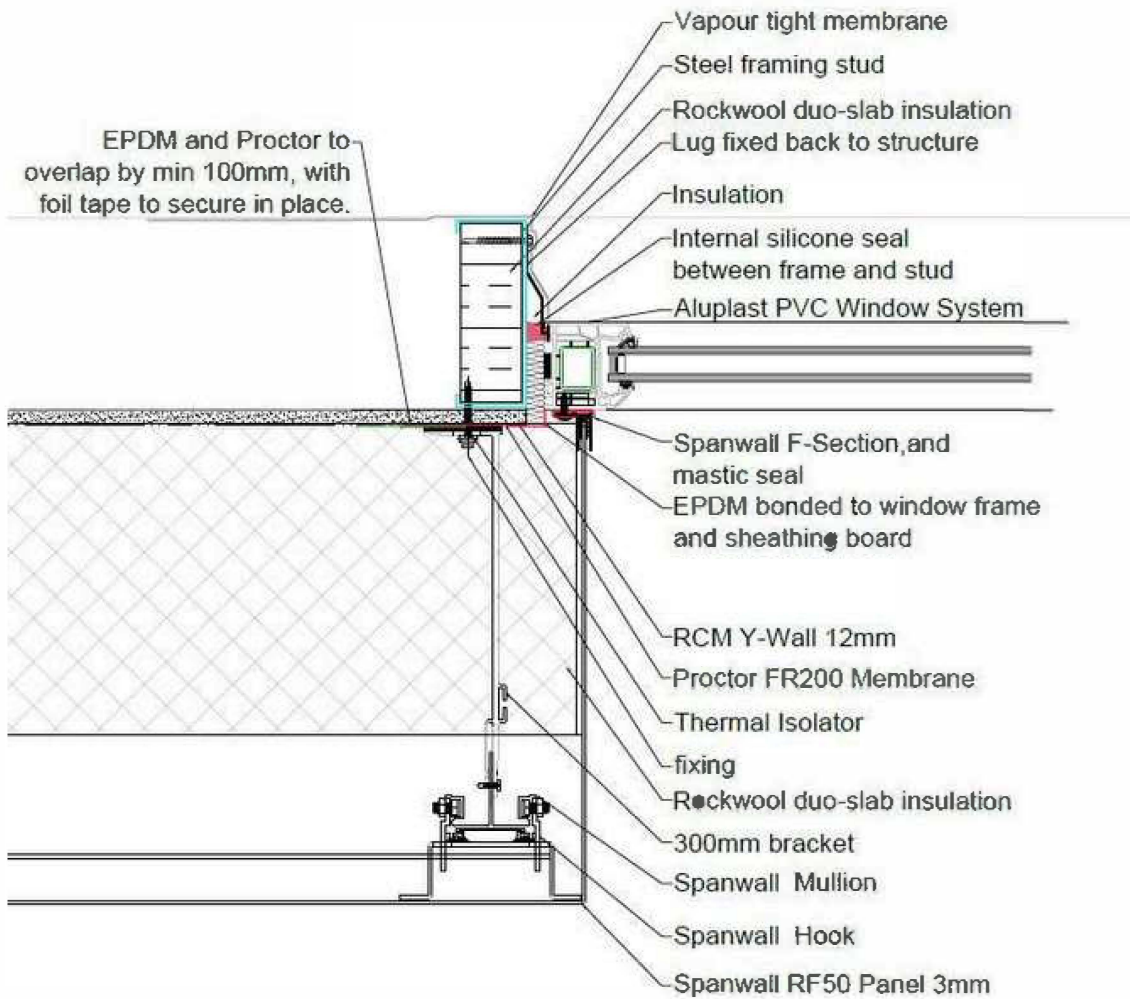

Window jamb details

Note: vapour tight membrane omitted from test sample internal

Hamilton

METAL FORMING LTD

Talk to us today...

Main Office

47 Shivey Rd,

Cookstown

BT80 9HB

Northern Ireland

T: +44 (0)28 8678 8505

E: sales@hamiltonmetalforming.com

www.hamiltonmetalforming.com

